

Different versions of stage-type projectors (from the top downwards): condenser projector and ellipsoidal projector with optical systems for projecting images, parabolic projector, projector for reflector lamps and Fresnel projector with variable beam angle.

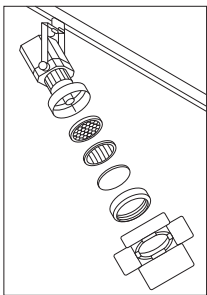

Accessories for spotlights and projectors: honeycomb anti-dazzle screen, sculpture lens, filter, anti-dazzle cylinder, barn doors.

### 2.7.2.2 Wallwashers

**Wallwashers** are not only available as stationary luminaires, but also as movable luminaires. In this case it is not so much the light direction that is variable, but the luminaire itself. On track, for example, movable wallwashers can provide temporary or permanent lighting on vertical surfaces. Movable wallwashers are generally equipped with halogen lamps for mains voltage, metal halide lamps or with fluorescent lamps (linear and compact types).

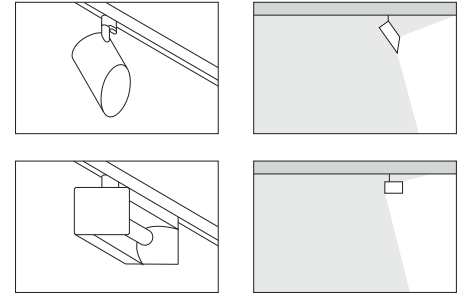

Different versions of movable wallwashers. They can be adjusted to different wall heights and distances.

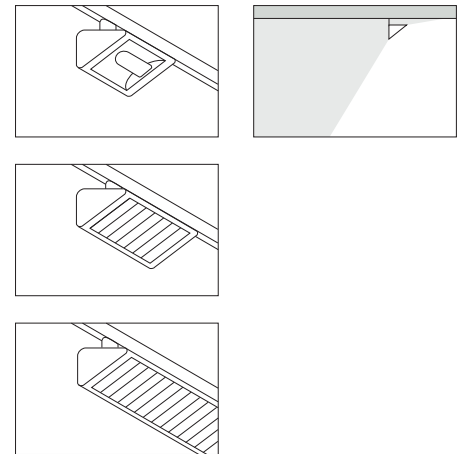

Wallwashers for halogen lamps, compact fluorescent lamps and linear fluorescent lamps.

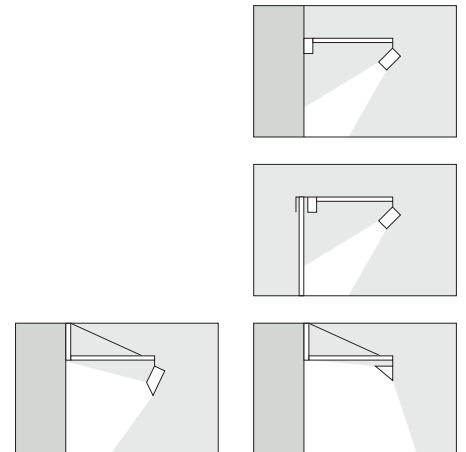

Cantilevers with integral transformer for low-voltage spotlights; wall-mounted (above) and mounted on a partition wall (centre). Cantilevers for the mounting of light structures and individual luminaires (below).

### 2.7.3 Light structures

**Light structures** are systems comprising modular elements that take integrated luminaires. Movable luminaires, e.g. spotlights, can be mounted and operated on light structures. They therefore allow a combination of stationary and movable luminaires.

Light structures can be formed of track, lattice beams, tubular profiles or panels. Their main feature is that they are modular systems, comprising standardised basic elements and a selection of connectors that allow the construction of a wide variety of structures – from linear arrangements to extensive grids. Light structures can therefore be incorporated into the surrounding architecture or themselves create architectural structures; they are designed to be highly functional lighting installations blending in harmoniously with their surroundings.

One sub-group of light structures are **carrier systems** with integral power supply. They are designed exclusively for the mounting and operation of movable luminaires. They can be track or tubular or panel systems with integral track.

Carrier systems can be mounted directly onto walls and ceilings, or suspended from the ceiling. Carrier systems with a high load-bearing capacity are also available as large-span structures.

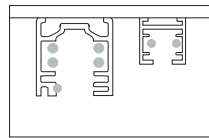

Three-circuit track for mains voltage and single-phase low-voltage track.

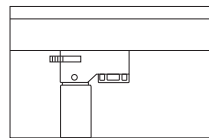

Adapter with phase selection switch for three-circuit track.

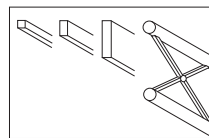

Different types of light structures: from track to large-span structures.

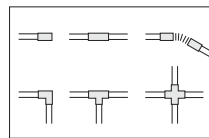

End cap, connector, flexible connector, L-connector, T-connector and X-connector for track.

Carrier system with downlight (top left), louvred luminaire (top right), ceiling washlights (bottom left) and uplight (bottom right).

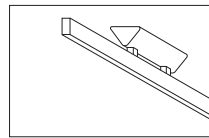
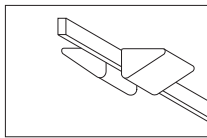
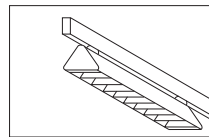
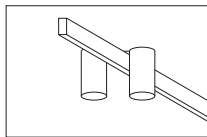

In the strict sense of the word **light structures** are characterised by the fact that they contain integral luminaires; if they also contain track or a series of connection points, they are also able to take movable luminaires, as required. They consist of tubular or panel elements and are usually suspended from the ceiling.

Light structures frequently consist of elements with integral louvred luminaires, which can be used for direct lighting and for indirect lighting by light reflected off the ceiling. For accent lighting elements with integral downlights or directional luminaires (frequently equipped with low-voltage lamps) can be used; decorative effects can be produced by elements with exposed incandescent or halogen lamps. Other elements can take information signs.

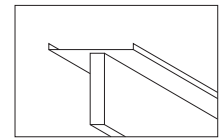
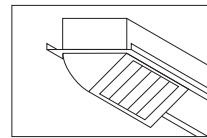
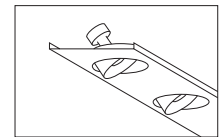
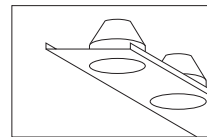
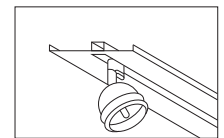
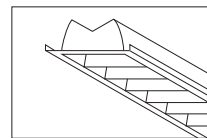
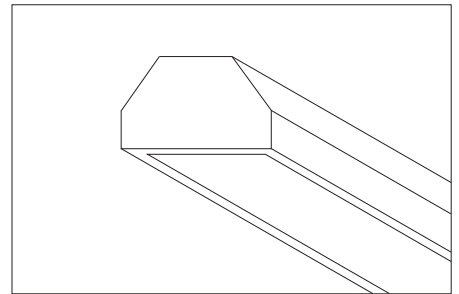

Light structure; empty profile with variety of attachments: louvred luminaires, downlights (also loudspeakers, connection points, etc., if required), wall-washers, track, directional spotlights and information signs.

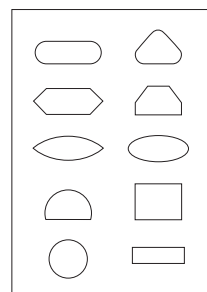

Cross sections of light structures showing a variety of profile designs.